

PHYS 406 - Fundamentals of Quantum Theory II

Term: Spring 2013
Meetings: Monday & Wednesday 15:15-16:30
Location: 106 Stuart Building

Instructor: Carlo Segre
Office: 166A Life Sciences
Phone: 312.567.3498
email: segre@iit.edu

Book: *Introduction to Quantum Mechanics, 2nd ed.*,
D. Griffiths (Pearson, 2005)

Web Site: <http://phys.iit.edu/~segre/phys406/13S>

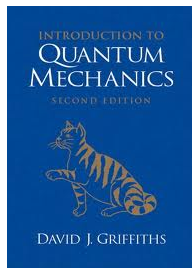

Course Objectives

- 1 Understand time-independent perturbation theory.

Course Objectives

- ① Understand time-independent perturbation theory.
- ② Understand the variational method.

Course Objectives

- ① Understand time-independent perturbation theory.
- ② Understand the variational method.
- ③ Understand the WKB and adiabatic approximations.

Course Objectives

- ① Understand time-independent perturbation theory.
- ② Understand the variational method.
- ③ Understand the WKB and adiabatic approximations.
- ④ Understand time-dependent perturbation theory.

Course Objectives

- ① Understand time-independent perturbation theory.
- ② Understand the variational method.
- ③ Understand the WKB and adiabatic approximations.
- ④ Understand time-dependent perturbation theory.
- ⑤ Understand scattering theory.

Course Objectives

- ① Understand time-independent perturbation theory.
- ② Understand the variational method.
- ③ Understand the WKB and adiabatic approximations.
- ④ Understand time-dependent perturbation theory.
- ⑤ Understand scattering theory.
- ⑥ Be able to solve quantum mechanics problems using the approximation method appropriate to the situation.

Course Grading

15% – Homework assignments

Course Grading

15% – Homework assignments
Weekly or bi-weekly

Course Grading

15% – Homework assignments
Weekly or bi-weekly
Due at beginning of class

Course Grading

15% – Homework assignments

Weekly or bi-weekly

Due at beginning of class

May be turned in via Blackboard

Course Grading

15% – Homework assignments

Weekly or bi-weekly

Due at beginning of class

May be turned in via Blackboard

50% – Two mid-term exams

Course Grading

15% – Homework assignments

Weekly or bi-weekly

Due at beginning of class

May be turned in via Blackboard

50% – Two mid-term exams

35% – Final examination

Course Grading

15% – Homework assignments

Weekly or bi-weekly

Due at beginning of class

May be turned in via Blackboard

50% – Two mid-term exams

35% – Final examination

Grading scale

A – 88% to 100%

B – 75% to 88%

C – 62% to 75%

D – 50% to 62%

E – 0% to 50%

Topics to be Covered (Chapter titles)

- 1 Time-independent perturbation theory

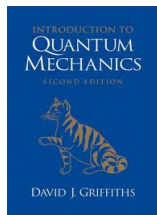

Topics to be Covered (Chapter titles)

- 1 Time-independent perturbation theory
- 2 Variational method

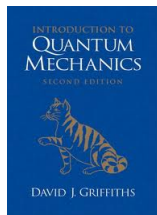

Topics to be Covered (Chapter titles)

- 1 Time-independent perturbation theory
- 2 Variational method
- 3 WKB approximation

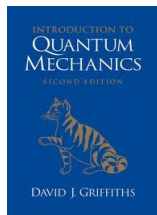

Topics to be Covered (Chapter titles)

- 1 Time-independent perturbation theory
- 2 Variational method
- 3 WKB approximation
- 4 Time-dependent perturbation theory

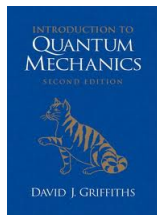

Topics to be Covered (Chapter titles)

- 1 Time-independent perturbation theory
- 2 Variational method
- 3 WKB approximation
- 4 Time-dependent perturbation theory
- 5 Adiabatic approximation

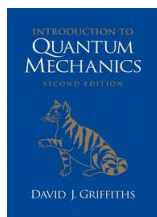

Topics to be Covered (Chapter titles)

- 1 Time-independent perturbation theory
- 2 Variational method
- 3 WKB approximation
- 4 Time-dependent perturbation theory
- 5 Adiabatic approximation
- 6 Scattering

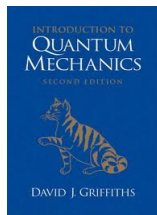

Topics to be Covered (Chapter titles)

- 1 Time-independent perturbation theory
- 2 Variational method
- 3 WKB approximation
- 4 Time-dependent perturbation theory
- 5 Adiabatic approximation
- 6 Scattering
- 7 Quantum paradoxes

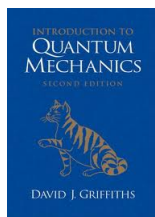

Topics to be Covered (Chapter titles)

- 1 Time-independent perturbation theory
- 2 Variational method
- 3 WKB approximation
- 4 Time-dependent perturbation theory
- 5 Adiabatic approximation
- 6 Scattering
- 7 Quantum paradoxes
- 8 Other topics as appropriate

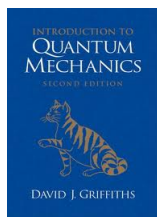

Course Schedule

Up-to-date schedule at

<http://phys.iit.edu/~segre/phys406/13S/schedule.html>

Course Schedule

Up-to-date schedule at

<http://phys.iit.edu/~segre/phys406/13S/schedule.html>

29 class sessions

Course Schedule

Up-to-date schedule at

<http://phys.iit.edu/~segre/phys406/13S/schedule.html>

29 class sessions

2 mid-term exams

Course Schedule

Up-to-date schedule at

<http://phys.iit.edu/~segre/phys406/13S/schedule.html>

29 class sessions

2 mid-term exams

~250 pages to cover

Course Schedule

Up-to-date schedule at

<http://phys.iit.edu/~segre/phys406/13S/schedule.html>

29 class sessions

2 mid-term exams

~250 pages to cover

~20 pages/week

Course Schedule

Up-to-date schedule at

<http://phys.iit.edu/~segre/phys406/13S/schedule.html>

29 class sessions

2 mid-term exams

~250 pages to cover

~20 pages/week

Focus on applications of quantum mechanics this semester.

Today's Outline - January 14, 2013

Today's Outline - January 14, 2013

- Tips for success

Today's Outline - January 14, 2013

- Tips for success
- Solids - free electron gas

Today's Outline - January 14, 2013

- Tips for success
- Solids - free electron gas
- Solids - band theory

Today's Outline - January 14, 2013

- Tips for success
- Solids - free electron gas
- Solids - band theory
- Quantum statistics

Today's Outline - January 14, 2013

- Tips for success
- Solids - free electron gas
- Solids - band theory
- Quantum statistics

Reading Assignment: Chapter 5.3–5.4, 6.1

Tips for success

- 1 Do the reading assignments before lecture, you will understand them better.

Tips for success

- ① Do the reading assignments before lecture, you will understand them better.
- ② Attend class or really view the lectures completely, there are things discussed which are not on the slides or the book.

Tips for success

- ① Do the reading assignments before lecture, you will understand them better.
- ② Attend class or really view the lectures completely, there are things discussed which are not on the slides or the book.
- ③ Ask questions in class, it's likely that others have the same ones.

Tips for success

- ① Do the reading assignments before lecture, you will understand them better.
- ② Attend class or really view the lectures completely, there are things discussed which are not on the slides or the book.
- ③ Ask questions in class, it's likely that others have the same ones.
- ④ Go through the derivations yourself, kill some trees!

Tips for success

- ① Do the reading assignments before lecture, you will understand them better.
- ② Attend class or really view the lectures completely, there are things discussed which are not on the slides or the book.
- ③ Ask questions in class, it's likely that others have the same ones.
- ④ Go through the derivations yourself, kill some trees!
- ⑤ Do the homework the “right” way, only use the solutions manual as a last resort.

Tips for success

- ① Do the reading assignments before lecture, you will understand them better.
- ② Attend class or really view the lectures completely, there are things discussed which are not on the slides or the book.
- ③ Ask questions in class, it's likely that others have the same ones.
- ④ Go through the derivations yourself, kill some trees!
- ⑤ Do the homework the “right” way, only use the solutions manual as a last resort.
- ⑥ Come to office hours with questions, I'll be less lonely and it will help you too!

Free electron gas

Solids are a particular example of a system of identical particles

Free electron gas

Solids are a particular example of a system of identical particles

The simplest model of a solid is the free electron gas

Free electron gas

Solids are a particular example of a system of identical particles

The simplest model of a solid is the free electron gas

- ignore all nuclei

Free electron gas

Solids are a particular example of a system of identical particles

The simplest model of a solid is the free electron gas

- ignore all nuclei
- ignore all core electrons

Free electron gas

Solids are a particular example of a system of identical particles

The simplest model of a solid is the free electron gas

- ignore all nuclei
- ignore all core electrons
- consider only the outermost valence electrons

Free electron gas

Solids are a particular example of a system of identical particles

The simplest model of a solid is the free electron gas

- ignore all nuclei
- ignore all core electrons
- consider only the outermost valence electrons
- no forces except for confining walls

Free electron gas

Solids are a particular example of a system of identical particles

The simplest model of a solid is the free electron gas

- ignore all nuclei
- ignore all core electrons
- consider only the outermost valence electrons
- no forces except for confining walls
- assume a rectangular parallelepiped (l_x, l_y, l_z)

Free electron gas

Solids are a particular example of a system of identical particles

The simplest model of a solid is the free electron gas

Treat as a 3-D particle-in-a-box system

- ignore all nuclei
- ignore all core electrons
- consider only the outermost valence electrons
- no forces except for confining walls
- assume a rectangular parallelepiped (l_x, l_y, l_z)

Free electron gas

Solids are a particular example of a system of identical particles

The simplest model of a solid is the free electron gas

Treat as a 3-D particle-in-a-box system

$$V(x, y, z) = \begin{cases} 0, & x, y, z \text{ in box} \\ \infty, & \text{otherwise} \end{cases}$$

- ignore all nuclei
- ignore all core electrons
- consider only the outermost valence electrons
- no forces except for confining walls
- assume a rectangular parallelepiped (l_x, l_y, l_z)

Free electron gas

Solids are a particular example of a system of identical particles

The simplest model of a solid is the free electron gas

Treat as a 3-D particle-in-a-box system

$$V(x, y, z) = \begin{cases} 0, & x, y, z \text{ in box} \\ \infty, & \text{otherwise} \end{cases}$$

$$-\frac{\hbar^2}{2m} \nabla^2 \psi = E \psi$$

- ignore all nuclei
- ignore all core electrons
- consider only the outermost valence electrons
- no forces except for confining walls
- assume a rectangular parallelepiped (l_x, l_y, l_z)

Free electron gas

Solids are a particular example of a system of identical particles

The simplest model of a solid is the free electron gas

Treat as a 3-D particle-in-a-box system

$$V(x, y, z) = \begin{cases} 0, & x, y, z \text{ in box} \\ \infty, & \text{otherwise} \end{cases}$$

$$-\frac{\hbar^2}{2m}\nabla^2\psi = E\psi, \quad \psi(x, y, z) = X(x)Y(y)Z(z)$$

- ignore all nuclei
- ignore all core electrons
- consider only the outermost valence electrons
- no forces except for confining walls
- assume a rectangular parallelepiped (l_x, l_y, l_z)

Free electron gas

Solids are a particular example of a system of identical particles

The simplest model of a solid is the free electron gas

Treat as a 3-D particle-in-a-box system

$$V(x, y, z) = \begin{cases} 0, & x, y, z \text{ in box} \\ \infty, & \text{otherwise} \end{cases}$$

$$-\frac{\hbar^2}{2m} \nabla^2 \psi = E \psi, \quad \psi(x, y, z) = X(x)Y(y)Z(z)$$

$$-\frac{\hbar^2}{2m} \frac{d^2 X}{dx^2} = E_x X, \quad -\frac{\hbar^2}{2m} \frac{d^2 Y}{dy^2} = E_y Y, \quad -\frac{\hbar^2}{2m} \frac{d^2 Z}{dz^2} = E_z Z$$

- ignore all nuclei
- ignore all core electrons
- consider only the outermost valence electrons
- no forces except for confining walls
- assume a rectangular parallelepiped (l_x, l_y, l_z)

3-D infinite square well

The total energy is thus

3-D infinite square well

The total energy is thus

$$E = E_x + E_y + E_z$$

3-D infinite square well

The total energy is thus
and we get the solutions

$$E = E_x + E_y + E_z$$

3-D infinite square well

The total energy is thus
and we get the solutions

$$k_x \equiv \frac{\sqrt{2mE_x}}{\hbar}$$

$$E = E_x + E_y + E_z$$

$$X(x) = A_x \sin(k_x x) + B_x \cos(k_x x)$$

3-D infinite square well

The total energy is thus
and we get the solutions

$$k_x \equiv \frac{\sqrt{2mE_x}}{\hbar}$$

$$k_y \equiv \frac{\sqrt{2mE_y}}{\hbar}$$

$$E = E_x + E_y + E_z$$

$$X(x) = A_x \sin(k_x x) + B_x \cos(k_x x)$$

$$Y(y) = A_y \sin(k_y y) + B_y \cos(k_y y)$$

3-D infinite square well

The total energy is thus
and we get the solutions

$$k_x \equiv \frac{\sqrt{2mE_x}}{\hbar}$$

$$k_y \equiv \frac{\sqrt{2mE_y}}{\hbar}$$

$$k_z \equiv \frac{\sqrt{2mE_z}}{\hbar}$$

$$E = E_x + E_y + E_z$$

$$X(x) = A_x \sin(k_x x) + B_x \cos(k_x x)$$

$$Y(y) = A_y \sin(k_y y) + B_y \cos(k_y y)$$

$$Z(z) = A_z \sin(k_z z) + B_z \cos(k_z z)$$

3-D infinite square well

The total energy is thus
and we get the solutions

$$k_x \equiv \frac{\sqrt{2mE_x}}{\hbar}$$

$$k_y \equiv \frac{\sqrt{2mE_y}}{\hbar}$$

$$k_z \equiv \frac{\sqrt{2mE_z}}{\hbar}$$

$$E = E_x + E_y + E_z$$

$$X(x) = A_x \sin(k_x x) + B_x \cos(k_x x)$$

$$Y(y) = A_y \sin(k_y y) + B_y \cos(k_y y)$$

$$Z(z) = A_z \sin(k_z z) + B_z \cos(k_z z)$$

The boundary conditions at the edges of the box impose quantization:

3-D infinite square well

The total energy is thus
and we get the solutions

$$k_x \equiv \frac{\sqrt{2mE_x}}{\hbar}$$

$$k_y \equiv \frac{\sqrt{2mE_y}}{\hbar}$$

$$k_z \equiv \frac{\sqrt{2mE_z}}{\hbar}$$

$$E = E_x + E_y + E_z$$

$$X(x) = A_x \sin(k_x x) + B_x \cos(k_x x)$$

$$Y(y) = A_y \sin(k_y y) + B_y \cos(k_y y)$$

$$Z(z) = A_z \sin(k_z z) + B_z \cos(k_z z)$$

The boundary conditions at the edges of the box impose quantization:

$$k_x l_x = n_x \pi$$
$$n_x = 1, 2, 3, \dots$$

3-D infinite square well

The total energy is thus
and we get the solutions

$$k_x \equiv \frac{\sqrt{2mE_x}}{\hbar}$$

$$k_y \equiv \frac{\sqrt{2mE_y}}{\hbar}$$

$$k_z \equiv \frac{\sqrt{2mE_z}}{\hbar}$$

$$E = E_x + E_y + E_z$$

$$X(x) = A_x \sin(k_x x) + B_x \cos(k_x x)$$

$$Y(y) = A_y \sin(k_y y) + B_y \cos(k_y y)$$

$$Z(z) = A_z \sin(k_z z) + B_z \cos(k_z z)$$

The boundary conditions at the edges of the box impose quantization:

$$\begin{aligned} k_x l_x &= n_x \pi, & k_y l_y &= n_y \pi \\ n_x &= 1, 2, 3, \dots, & n_y &= 1, 2, 3, \dots \end{aligned}$$

3-D infinite square well

The total energy is thus
and we get the solutions

$$k_x \equiv \frac{\sqrt{2mE_x}}{\hbar}$$

$$k_y \equiv \frac{\sqrt{2mE_y}}{\hbar}$$

$$k_z \equiv \frac{\sqrt{2mE_z}}{\hbar}$$

$$E = E_x + E_y + E_z$$

$$X(x) = A_x \sin(k_x x) + B_x \cos(k_x x)$$

$$Y(y) = A_y \sin(k_y y) + B_y \cos(k_y y)$$

$$Z(z) = A_z \sin(k_z z) + B_z \cos(k_z z)$$

The boundary conditions at the edges of the box impose quantization:

$$\begin{aligned} k_x l_x &= n_x \pi, & k_y l_y &= n_y \pi, & k_z l_z &= n_z \pi \\ n_x &= 1, 2, 3, \dots, & n_y &= 1, 2, 3, \dots, & n_z &= 1, 2, 3, \dots \end{aligned}$$

3-D infinite square well

The total energy is thus

$$E = E_x + E_y + E_z$$

and we get the solutions

$$k_x \equiv \frac{\sqrt{2mE_x}}{\hbar}$$

$$X(x) = A_x \sin(k_x x) + B_x \cos(k_x x)$$

$$k_y \equiv \frac{\sqrt{2mE_y}}{\hbar}$$

$$Y(y) = A_y \sin(k_y y) + B_y \cos(k_y y)$$

$$k_z \equiv \frac{\sqrt{2mE_z}}{\hbar}$$

$$Z(z) = A_z \sin(k_z z) + B_z \cos(k_z z)$$

The boundary conditions at the edges of the box impose quantization:

$$k_x l_x = n_x \pi, \quad k_y l_y = n_y \pi, \quad k_z l_z = n_z \pi$$
$$n_x = 1, 2, 3, \dots, \quad n_y = 1, 2, 3, \dots, \quad n_z = 1, 2, 3, \dots$$

$$\psi_{n_x n_y n_z} = \sqrt{\frac{8}{l_x l_y l_z}} \sin\left(\frac{n_x \pi}{l_x} x\right) \sin\left(\frac{n_y \pi}{l_y} y\right) \sin\left(\frac{n_z \pi}{l_z} z\right)$$

Reciprocal space

The energy of the 3-D states is

Reciprocal space

The energy of the 3-D states is

$$E_{n_x n_y n_z} = \frac{\hbar^2 \pi^2}{2m} \left(\frac{n_x^2}{l_x^2} + \frac{n_y^2}{l_y^2} + \frac{n_z^2}{l_z^2} \right)$$

Reciprocal space

The energy of the 3-D states is

$$\begin{aligned} E_{n_x n_y n_z} &= \frac{\hbar^2 \pi^2}{2m} \left(\frac{n_x^2}{l_x^2} + \frac{n_y^2}{l_y^2} + \frac{n_z^2}{l_z^2} \right) \\ &= \frac{\hbar^2 k^2}{2m} \end{aligned}$$

Reciprocal space

The energy of the 3-D states is

$$\begin{aligned} E_{n_x n_y n_z} &= \frac{\hbar^2 \pi^2}{2m} \left(\frac{n_x^2}{l_x^2} + \frac{n_y^2}{l_y^2} + \frac{n_z^2}{l_z^2} \right) \\ &= \frac{\hbar^2 k^2}{2m} \end{aligned}$$

these discrete values of k_x , k_y , k_z form a lattice called the reciprocal lattice.

Reciprocal space

The energy of the 3-D states is

$$E_{n_x n_y n_z} = \frac{\hbar^2 \pi^2}{2m} \left(\frac{n_x^2}{l_x^2} + \frac{n_y^2}{l_y^2} + \frac{n_z^2}{l_z^2} \right)$$
$$= \frac{\hbar^2 k^2}{2m}$$

these discrete values of k_x , k_y , k_z form a lattice called the reciprocal lattice.

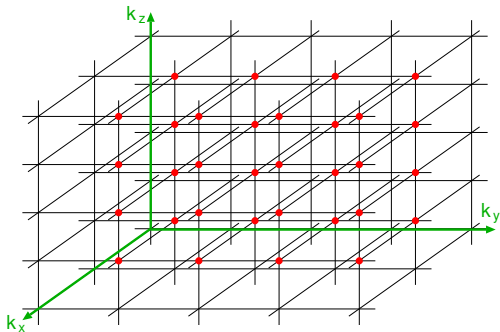

Reciprocal space

The energy of the 3-D states is

$$\begin{aligned} E_{n_x n_y n_z} &= \frac{\hbar^2 \pi^2}{2m} \left(\frac{n_x^2}{l_x^2} + \frac{n_y^2}{l_y^2} + \frac{n_z^2}{l_z^2} \right) \\ &= \frac{\hbar^2 k^2}{2m} \end{aligned}$$

these discrete values of k_x , k_y , k_z form a lattice called the reciprocal lattice.

each point is a discrete single particle state

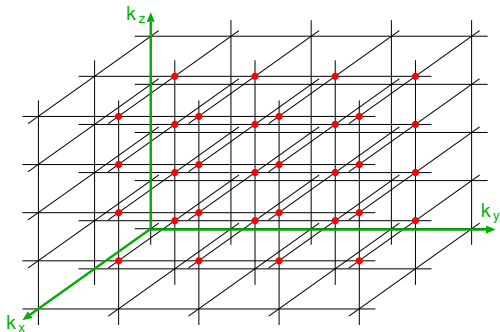

Volume of reciprocal lattice point

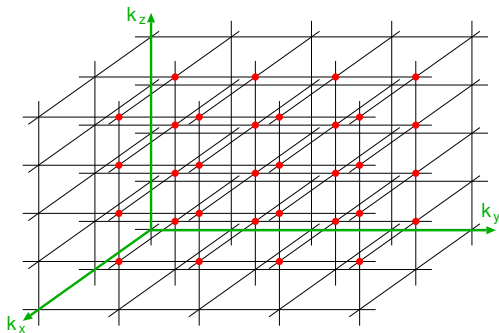

Volume of reciprocal lattice point

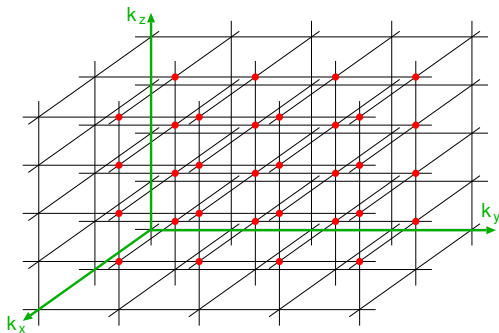

What is the volume, in reciprocal space, occupied by each of these states?

Volume of reciprocal lattice point

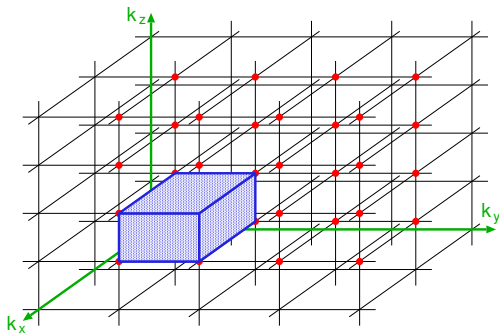

What is the volume, in reciprocal space, occupied by each of these states?

start by drawing a rectangular box with a point at each corner

Volume of reciprocal lattice point

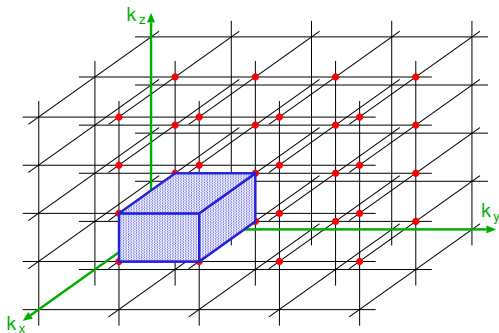

What is the volume, in reciprocal space, occupied by each of these states?

start by drawing a rectangular box with a point at each corner which represents the volume occupied by one point

Volume of reciprocal lattice point

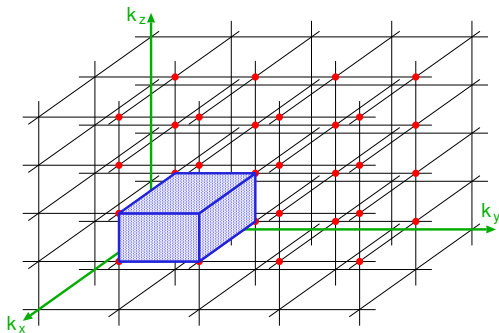

What is the volume, in reciprocal space, occupied by each of these states?

start by drawing a rectangular box with a point at each corner which represents the volume occupied by one point

$$\Delta k_x \cdot \Delta k_y \cdot \Delta k_z = \frac{\pi}{l_x} \cdot \frac{\pi}{l_y} \cdot \frac{\pi}{l_z}$$

Volume of reciprocal lattice point

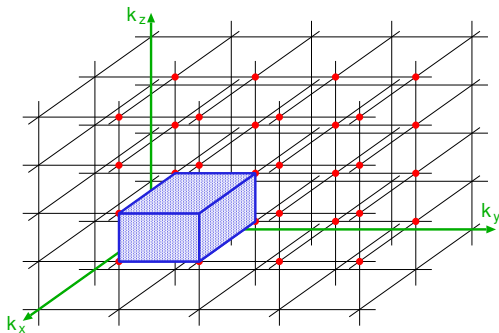

What is the volume, in reciprocal space, occupied by each of these states?

start by drawing a rectangular box with a point at each corner which represents the volume occupied by one point

$$\Delta k_x \cdot \Delta k_y \cdot \Delta k_z = \frac{\pi}{l_x} \cdot \frac{\pi}{l_y} \cdot \frac{\pi}{l_z} = \frac{\pi^3}{l_x l_y l_z}$$

Volume of reciprocal lattice point

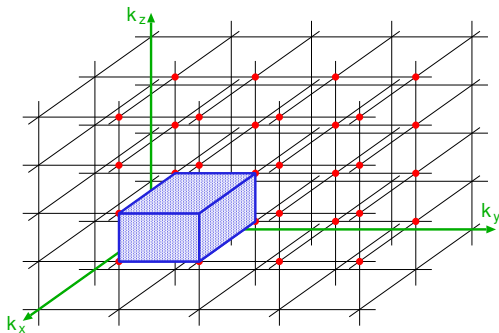

What is the volume, in reciprocal space, occupied by each of these states?

start by drawing a rectangular box with a point at each corner which represents the volume occupied by one point

$$\Delta k_x \cdot \Delta k_y \cdot \Delta k_z = \frac{\pi}{l_x} \cdot \frac{\pi}{l_y} \cdot \frac{\pi}{l_z} = \frac{\pi^3}{l_x l_y l_z} = \frac{\pi^3}{V}$$

Volume of reciprocal lattice point

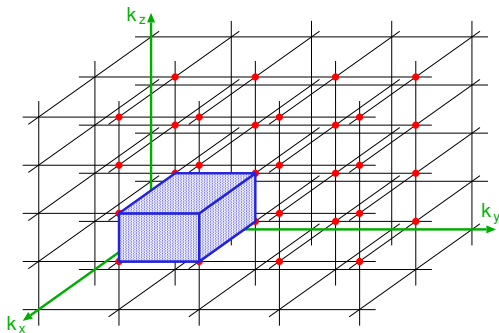

What is the volume, in reciprocal space, occupied by each of these states?

start by drawing a rectangular box with a point at each corner which represents the volume occupied by one point

$$\Delta k_x \cdot \Delta k_y \cdot \Delta k_z = \frac{\pi}{l_x} \cdot \frac{\pi}{l_y} \cdot \frac{\pi}{l_z} = \frac{\pi^3}{l_x l_y l_z} = \frac{\pi^3}{V}$$

if the solid contains N atoms and each atom contributes q free electrons to the electron gas, we can begin to see how the states in reciprocal space are populated

Fermi level

Since electrons are fermions, only two (spin up and spin down) can occupy each single particle state.

Fermi level

Since electrons are fermions, only two (spin up and spin down) can occupy each single particle state. As we fill states starting with the lowest energies, the occupied states begin to fill an octant of a sphere in k -space.

Fermi level

Since electrons are fermions, only two (spin up and spin down) can occupy each single particle state. As we fill states starting with the lowest energies, the occupied states begin to fill an octant of a sphere in k -space.

The radius of this sphere is called k_F and the volume of the octant is given by

Fermi level

Since electrons are fermions, only two (spin up and spin down) can occupy each single particle state. As we fill states starting with the lowest energies, the occupied states begin to fill an octant of a sphere in k -space.

The radius of this sphere is called k_F and the volume of the octant is given by

$$\frac{1}{8} \left(\frac{4}{3} \pi k_F^3 \right) = \frac{Nq}{2} \left(\frac{\pi^3}{V} \right)$$

Fermi level

Since electrons are fermions, only two (spin up and spin down) can occupy each single particle state. As we fill states starting with the lowest energies, the occupied states begin to fill an octant of a sphere in k -space.

The radius of this sphere is called k_F and the volume of the octant is given by

defining $\rho = Nq/V$ as the density of free electrons per unit volume, we have

$$\frac{1}{8} \left(\frac{4}{3} \pi k_F^3 \right) = \frac{Nq}{2} \left(\frac{\pi^3}{V} \right)$$

Fermi level

Since electrons are fermions, only two (spin up and spin down) can occupy each single particle state. As we fill states starting with the lowest energies, the occupied states begin to fill an octant of a sphere in k -space.

The radius of this sphere is called k_F and the volume of the octant is given by

defining $\rho = Nq/V$ as the density of free electrons per unit volume, we have

$$\frac{1}{8} \left(\frac{4}{3} \pi k_F^3 \right) = \frac{Nq}{2} \left(\frac{\pi^3}{V} \right)$$
$$k_F = (3\rho\pi^2)^{1/3}$$

Fermi level

Since electrons are fermions, only two (spin up and spin down) can occupy each single particle state. As we fill states starting with the lowest energies, the occupied states begin to fill an octant of a sphere in k -space.

The radius of this sphere is called k_F and the volume of the octant is given by

defining $\rho = Nq/V$ as the density of free electrons per unit volume, we have

$$\frac{1}{8} \left(\frac{4}{3} \pi k_F^3 \right) = \frac{Nq}{2} \left(\frac{\pi^3}{V} \right)$$
$$k_F = (3\rho\pi^2)^{1/3}$$

k_F defines the Fermi surface and the corresponding Fermi energy is given by

Fermi level

Since electrons are fermions, only two (spin up and spin down) can occupy each single particle state. As we fill states starting with the lowest energies, the occupied states begin to fill an octant of a sphere in k -space.

The radius of this sphere is called k_F and the volume of the octant is given by

defining $\rho = Nq/V$ as the density of free electrons per unit volume, we have

k_F defines the Fermi surface and the corresponding Fermi energy is given by

$$\begin{aligned}\frac{1}{8} \left(\frac{4}{3} \pi k_F^3 \right) &= \frac{Nq}{2} \left(\frac{\pi^3}{V} \right) \\ k_F &= (3\rho\pi^2)^{1/3} \\ E_F &= \frac{\hbar^2}{2m} (3\rho\pi^2)^{2/3}\end{aligned}$$

Energy of a Fermi shell

We may now calculate the total energy of the electron gas by considering a shell of this octant with thickness dk

Energy of a Fermi shell

We may now calculate the total energy of the electron gas by considering a shell of this octant with thickness dk

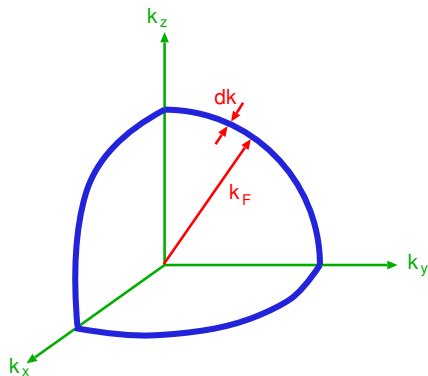

Energy of a Fermi shell

We may now calculate the total energy of the electron gas by considering a shell of this octant with thickness dk

the volume of the shell is

$$\frac{1}{8}(4\pi k^2)dk = \frac{1}{2}\pi k^2 dk$$

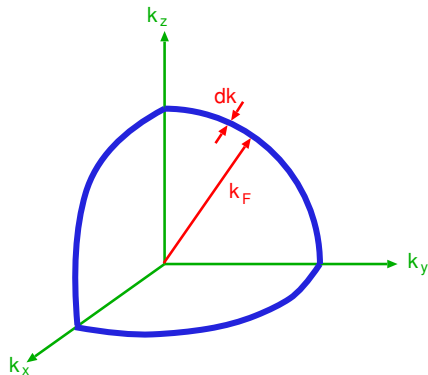

Energy of a Fermi shell

We may now calculate the total energy of the electron gas by considering a shell of this octant with thickness dk

the volume of the shell is

$$\frac{1}{8}(4\pi k^2)dk = \frac{1}{2}\pi k^2 dk$$

the number of states in the shell is then

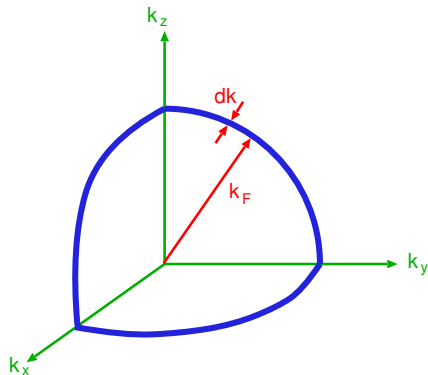

Energy of a Fermi shell

We may now calculate the total energy of the electron gas by considering a shell of this octant with thickness dk

the volume of the shell is

$$\frac{1}{8}(4\pi k^2)dk = \frac{1}{2}\pi k^2 dk$$

the number of states in the shell is then

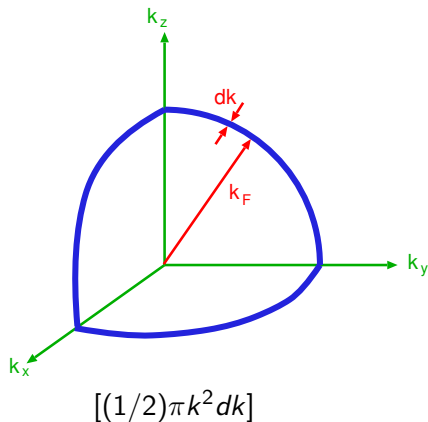

Energy of a Fermi shell

We may now calculate the total energy of the electron gas by considering a shell of this octant with thickness dk

the volume of the shell is

$$\frac{1}{8}(4\pi k^2)dk = \frac{1}{2}\pi k^2 dk$$

the number of states in the shell is then

$$\frac{[(1/2)\pi k^2 dk]}{(\pi^3/V)}$$

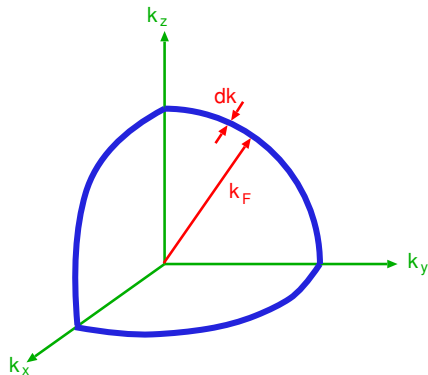

Energy of a Fermi shell

We may now calculate the total energy of the electron gas by considering a shell of this octant with thickness dk

the volume of the shell is

$$\frac{1}{8}(4\pi k^2)dk = \frac{1}{2}\pi k^2 dk$$

the number of states in the shell is then

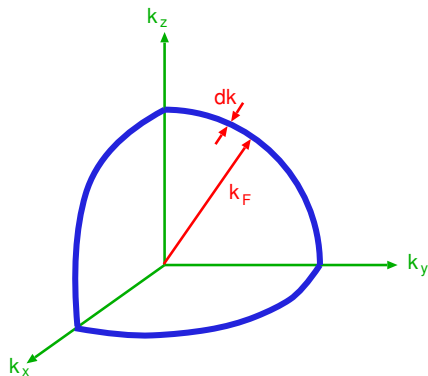

$$\frac{2[(1/2)\pi k^2 dk]}{(\pi^3/V)}$$

Energy of a Fermi shell

We may now calculate the total energy of the electron gas by considering a shell of this octant with thickness dk

the volume of the shell is

$$\frac{1}{8}(4\pi k^2)dk = \frac{1}{2}\pi k^2 dk$$

the number of states in the shell is then

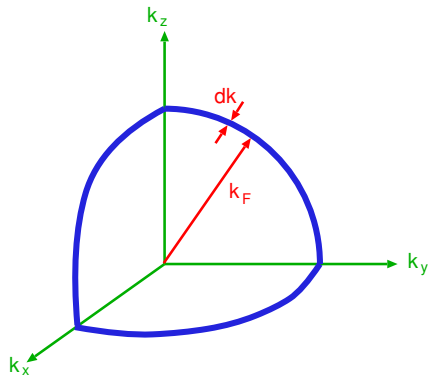

$$\frac{2[(1/2)\pi k^2 dk]}{(\pi^3/V)} = \frac{V}{\pi^2} k^2 dk$$

Energy of a Fermi shell

We may now calculate the total energy of the electron gas by considering a shell of this octant with thickness dk

the volume of the shell is

$$\frac{1}{8}(4\pi k^2)dk = \frac{1}{2}\pi k^2 dk$$

the number of states in the shell is then

since each state has an energy $\hbar^2 k^2/2m$, the total energy of the states in the shell is

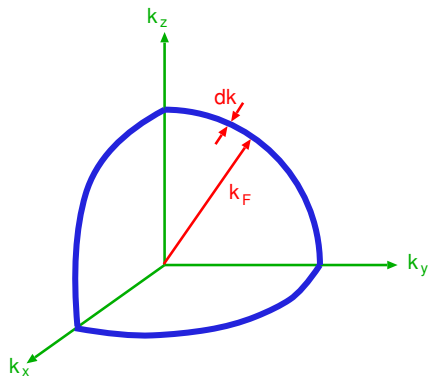

$$\frac{2[(1/2)\pi k^2 dk]}{(\pi^3/V)} = \frac{V}{\pi^2} k^2 dk$$

Energy of a Fermi shell

We may now calculate the total energy of the electron gas by considering a shell of this octant with thickness dk

the volume of the shell is

$$\frac{1}{8}(4\pi k^2)dk = \frac{1}{2}\pi k^2 dk$$

the number of states in the shell is then

since each state has an energy $\hbar^2 k^2/2m$, the total energy of the states in the shell is

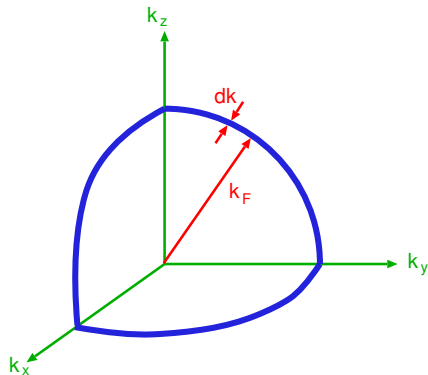

$$\frac{2[(1/2)\pi k^2 dk]}{(\pi^3/V)} = \frac{V}{\pi^2} k^2 dk$$
$$dE = \frac{\hbar^2 k^4}{2m} \frac{V}{\pi^2} dk$$

Total energy of the gas

The total energy of the gas is therefore given by integrating

Total energy of the gas

The total energy of the gas is therefore given by integrating

$$E_{\text{tot}} = \frac{\hbar^2 V}{2\pi^2 m} \int_0^{k_F} k^4 dk$$

Total energy of the gas

The total energy of the gas is therefore given by integrating

$$E_{\text{tot}} = \frac{\hbar^2 V}{2\pi^2 m} \int_0^{k_F} k^4 dk = \frac{\hbar^2 k_F^5 V}{10\pi^2 m}$$

Total energy of the gas

The total energy of the gas is therefore given by integrating

$$E_{\text{tot}} = \frac{\hbar^2 V}{2\pi^2 m} \int_0^{k_F} k^4 dk = \frac{\hbar^2 k_F^5 V}{10\pi^2 m} = \frac{\hbar^2 (3\pi^2 Nq)^{5/3}}{10\pi^2 m} V^{-2/3}$$

Total energy of the gas

The total energy of the gas is therefore given by integrating

$$E_{tot} = \frac{\hbar^2 V}{2\pi^2 m} \int_0^{k_F} k^4 dk = \frac{\hbar^2 k_F^5 V}{10\pi^2 m} = \frac{\hbar^2 (3\pi^2 Nq)^{5/3}}{10\pi^2 m} V^{-2/3}$$

If we now look at how the total energy depends on a small change of the volume of the solid

Total energy of the gas

The total energy of the gas is therefore given by integrating

$$E_{tot} = \frac{\hbar^2 V}{2\pi^2 m} \int_0^{k_F} k^4 dk = \frac{\hbar^2 k_F^5 V}{10\pi^2 m} = \frac{\hbar^2 (3\pi^2 Nq)^{5/3}}{10\pi^2 m} V^{-2/3}$$

If we now look at how the total energy depends on a small change of the volume of the solid

$$\frac{dE_{tot}}{dV} = -\frac{2}{3} \frac{\hbar^2 (3\pi^2 Nq)^{5/3}}{10\pi^2 m} V^{-5/3}$$

Total energy of the gas

The total energy of the gas is therefore given by integrating

$$E_{tot} = \frac{\hbar^2 V}{2\pi^2 m} \int_0^{k_F} k^4 dk = \frac{\hbar^2 k_F^5 V}{10\pi^2 m} = \frac{\hbar^2 (3\pi^2 Nq)^{5/3}}{10\pi^2 m} V^{-2/3}$$

If we now look at how the total energy depends on a small change of the volume of the solid

$$\frac{dE_{tot}}{dV} = -\frac{2}{3} \frac{\hbar^2 (3\pi^2 Nq)^{5/3}}{10\pi^2 m} V^{-5/3}$$

$$dE_{tot} = -\frac{2}{3} E_{tot} \frac{dV}{V}$$

Total energy of the gas

The total energy of the gas is therefore given by integrating

$$E_{tot} = \frac{\hbar^2 V}{2\pi^2 m} \int_0^{k_F} k^4 dk = \frac{\hbar^2 k_F^5 V}{10\pi^2 m} = \frac{\hbar^2 (3\pi^2 Nq)^{5/3}}{10\pi^2 m} V^{-2/3}$$

If we now look at how the total energy depends on a small change of the volume of the solid

$$\frac{dE_{tot}}{dV} = -\frac{2}{3} \frac{\hbar^2 (3\pi^2 Nq)^{5/3}}{10\pi^2 m} V^{-5/3}$$

$$dE_{tot} = -\frac{2}{3} E_{tot} \frac{dV}{V} = dW$$

this is equivalent to a pressure exerted by the gas which does work and changes the energy of the gas

Total energy of the gas

The total energy of the gas is therefore given by integrating

$$E_{tot} = \frac{\hbar^2 V}{2\pi^2 m} \int_0^{k_F} k^4 dk = \frac{\hbar^2 k_F^5 V}{10\pi^2 m} = \frac{\hbar^2 (3\pi^2 Nq)^{5/3}}{10\pi^2 m} V^{-2/3}$$

If we now look at how the total energy depends on a small change of the volume of the solid

$$\frac{dE_{tot}}{dV} = -\frac{2}{3} \frac{\hbar^2 (3\pi^2 Nq)^{5/3}}{10\pi^2 m} V^{-5/3}$$

$$dE_{tot} = -\frac{2}{3} E_{tot} \frac{dV}{V} = dW$$

this is equivalent to a pressure exerted by the gas which does work and changes the energy of the gas

$$P = -\frac{2}{3} \frac{E_{tot}}{V}$$

Total energy of the gas

The total energy of the gas is therefore given by integrating

$$E_{tot} = \frac{\hbar^2 V}{2\pi^2 m} \int_0^{k_F} k^4 dk = \frac{\hbar^2 k_F^5 V}{10\pi^2 m} = \frac{\hbar^2 (3\pi^2 Nq)^{5/3}}{10\pi^2 m} V^{-2/3}$$

If we now look at how the total energy depends on a small change of the volume of the solid

$$\frac{dE_{tot}}{dV} = -\frac{2}{3} \frac{\hbar^2 (3\pi^2 Nq)^{5/3}}{10\pi^2 m} V^{-5/3}$$

$$dE_{tot} = -\frac{2}{3} E_{tot} \frac{dV}{V} = dW$$

this is equivalent to a pressure exerted by the gas which does work and changes the energy of the gas

$$P = -\frac{2}{3} \frac{E_{tot}}{V} = \frac{2}{3} \frac{\hbar^2 k_F^5}{10\pi^2 m}$$

Total energy of the gas

The total energy of the gas is therefore given by integrating

$$E_{tot} = \frac{\hbar^2 V}{2\pi^2 m} \int_0^{k_F} k^4 dk = \frac{\hbar^2 k_F^5 V}{10\pi^2 m} = \frac{\hbar^2 (3\pi^2 Nq)^{5/3}}{10\pi^2 m} V^{-2/3}$$

If we now look at how the total energy depends on a small change of the volume of the solid

$$\frac{dE_{tot}}{dV} = -\frac{2}{3} \frac{\hbar^2 (3\pi^2 Nq)^{5/3}}{10\pi^2 m} V^{-5/3}$$

$$dE_{tot} = -\frac{2}{3} E_{tot} \frac{dV}{V} = dW$$

this is equivalent to a pressure exerted by the gas which does work and changes the energy of the gas

$$\begin{aligned} P &= -\frac{2}{3} \frac{E_{tot}}{V} = \frac{2}{3} \frac{\hbar^2 k_F^5}{10\pi^2 m} \\ &= \frac{(3\pi^2)^{2/3} \hbar^2}{5m} \rho^{5/3} \end{aligned}$$

Band theory

A better model is one which includes the periodic potential of the positive ions in a solid.

Band theory

A better model is one which includes the periodic potential of the positive ions in a solid.

This can be demonstrated by a simple 1-D model called the Dirac comb but is generalizable to any potential with the same mathematical characteristics.

Band theory

A better model is one which includes the periodic potential of the positive ions in a solid.

This can be demonstrated by a simple 1-D model called the Dirac comb but is generalizable to any potential with the same mathematical characteristics.

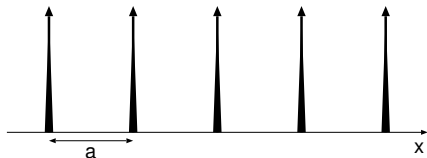

Band theory

A better model is one which includes the periodic potential of the positive ions in a solid.

This can be demonstrated by a simple 1-D model called the Dirac comb but is generalizable to any potential with the same mathematical characteristics.

The Dirac comb is a periodic potential, that is

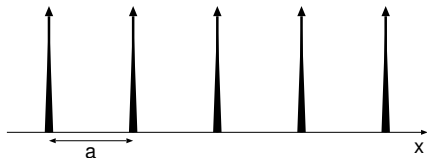

Band theory

A better model is one which includes the periodic potential of the positive ions in a solid.

This can be demonstrated by a simple 1-D model called the Dirac comb but is generalizable to any potential with the same mathematical characteristics.

The Dirac comb is a periodic potential, that is

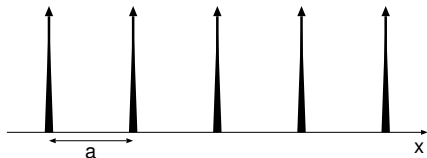

$$V(x + a) = V(x)$$

Band theory

A better model is one which includes the periodic potential of the positive ions in a solid.

This can be demonstrated by a simple 1-D model called the Dirac comb but is generalizable to any potential with the same mathematical characteristics.

The Dirac comb is a periodic potential, that is

where a is the distance between the repeating potential features

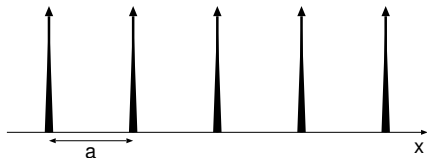

$$V(x + a) = V(x)$$

Band theory

A better model is one which includes the periodic potential of the positive ions in a solid.

This can be demonstrated by a simple 1-D model called the Dirac comb but is generalizable to any potential with the same mathematical characteristics.

The Dirac comb is a periodic potential, that is

where a is the distance between the repeating potential features

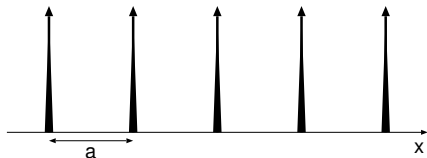

$$V(x + a) = V(x)$$

$$H = -\frac{\hbar^2}{2m} \frac{d^2}{dx^2} + V(x)$$

Band theory

A better model is one which includes the periodic potential of the positive ions in a solid.

This can be demonstrated by a simple 1-D model called the Dirac comb but is generalizable to any potential with the same mathematical characteristics.

The Dirac comb is a periodic potential, that is

where a is the distance between the repeating potential features

we can define an operator D , called the displacement operator, which describes the translational symmetry of the potential

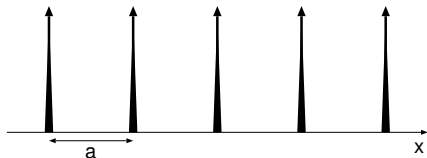

$$V(x + a) = V(x)$$

$$H = -\frac{\hbar^2}{2m} \frac{d^2}{dx^2} + V(x)$$

Band theory

A better model is one which includes the periodic potential of the positive ions in a solid.

This can be demonstrated by a simple 1-D model called the Dirac comb but is generalizable to any potential with the same mathematical characteristics.

The Dirac comb is a periodic potential, that is

where a is the distance between the repeating potential features

we can define an operator D , called the displacement operator, which describes the translational symmetry of the potential

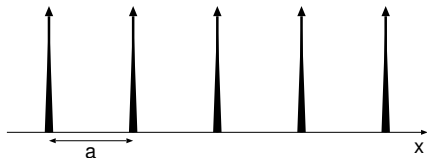

$$V(x + a) = V(x)$$

$$H = -\frac{\hbar^2}{2m} \frac{d^2}{dx^2} + V(x)$$

$$D f(x) = f(x + a)$$

Properties of the displacement operator

The solution to the Dirac comb must be an eigenfunction of the Hamiltonian but how will it transform under the displacement operator?

Properties of the displacement operator

The solution to the Dirac comb must be an eigenfunction of the Hamiltonian but how will it transform under the displacement operator?

To determine this, let's compute the commutator of D and H ,

$$[D, H] = DH - HD$$

Properties of the displacement operator

The solution to the Dirac comb must be an eigenfunction of the Hamiltonian but how will it transform under the displacement operator?

To determine this, let's compute the commutator of D and H ,

$$[D, H] = DH - HD$$

Properties of the displacement operator

The solution to the Dirac comb must be an eigenfunction of the Hamiltonian but how will it transform under the displacement operator?

To determine this, let's compute the commutator of D and H ,

$$[D, H] = DH - HD$$

$$[D, H] f(x) = \quad -$$

Properties of the displacement operator

The solution to the Dirac comb must be an eigenfunction of the Hamiltonian but how will it transform under the displacement operator?

To determine this, let's compute the commutator of D and H ,

$$[D, H] = DH - HD$$

$$[D, H] f(x) = D\left[-\frac{\hbar^2}{2m} \frac{d^2}{dx^2} + V(x)\right]f(x) -$$

Properties of the displacement operator

The solution to the Dirac comb must be an eigenfunction of the Hamiltonian but how will it transform under the displacement operator?

To determine this, let's compute the commutator of D and H ,

$$[D, H] = DH - HD$$

$$[D, H] f(x) = D\left[-\frac{\hbar^2}{2m} \frac{d^2}{dx^2} + V(x)\right]f(x) - \left[-\frac{\hbar^2}{2m} \frac{d^2}{dx^2} + V(x)\right]Df(x)$$

Properties of the displacement operator

The solution to the Dirac comb must be an eigenfunction of the Hamiltonian but how will it transform under the displacement operator?

To determine this, let's compute the commutator of D and H ,

$$[D, H] = DH - HD$$

$$\begin{aligned} [D, H] f(x) &= D\left[-\frac{\hbar^2}{2m} \frac{d^2}{dx^2} + V(x)\right]f(x) - \left[-\frac{\hbar^2}{2m} \frac{d^2}{dx^2} + V(x)\right]Df(x) \\ &= D\left[-\frac{\hbar^2}{2m} f''(x) + V(x)f(x)\right] \end{aligned}$$

Properties of the displacement operator

The solution to the Dirac comb must be an eigenfunction of the Hamiltonian but how will it transform under the displacement operator?

To determine this, let's compute the commutator of D and H ,

$$[D, H] = DH - HD$$

$$\begin{aligned} [D, H] f(x) &= D\left[-\frac{\hbar^2}{2m} \frac{d^2}{dx^2} + V(x)\right]f(x) - \left[-\frac{\hbar^2}{2m} \frac{d^2}{dx^2} + V(x)\right]Df(x) \\ &= D\left[-\frac{\hbar^2}{2m} f''(x) + V(x)f(x)\right] - \left[-\frac{\hbar^2}{2m} \frac{d^2}{dx^2} + V(x)\right]f(x+a) \end{aligned}$$

Properties of the displacement operator

The solution to the Dirac comb must be an eigenfunction of the Hamiltonian but how will it transform under the displacement operator?

To determine this, let's compute the commutator of D and H ,

$$[D, H] = DH - HD$$

$$\begin{aligned}[D, H] f(x) &= D\left[-\frac{\hbar^2}{2m} \frac{d^2}{dx^2} + V(x)\right]f(x) - \left[-\frac{\hbar^2}{2m} \frac{d^2}{dx^2} + V(x)\right]Df(x) \\ &= D\left[-\frac{\hbar^2}{2m} f''(x) + V(x)f(x)\right] - \left[-\frac{\hbar^2}{2m} \frac{d^2}{dx^2} + V(x)\right]f(x+a) \\ &= \left[-\frac{\hbar^2}{2m} f''(x+a) + V(x+a)f(x+a)\right]\end{aligned}$$

Properties of the displacement operator

The solution to the Dirac comb must be an eigenfunction of the Hamiltonian but how will it transform under the displacement operator?

To determine this, let's compute the commutator of D and H ,

$$[D, H] = DH - HD$$

$$\begin{aligned}[D, H] f(x) &= D\left[-\frac{\hbar^2}{2m} \frac{d^2}{dx^2} + V(x)\right]f(x) - \left[-\frac{\hbar^2}{2m} \frac{d^2}{dx^2} + V(x)\right]Df(x) \\ &= D\left[-\frac{\hbar^2}{2m} f''(x) + V(x)f(x)\right] - \left[-\frac{\hbar^2}{2m} \frac{d^2}{dx^2} + V(x)\right]f(x+a) \\ &= \left[-\frac{\hbar^2}{2m} f''(x+a) + V(x+a)f(x+a)\right] \\ &\quad - \left[-\frac{\hbar^2}{2m} f''(x+a) + V(x)f(x+a)\right]\end{aligned}$$

Properties of the displacement operator

The solution to the Dirac comb must be an eigenfunction of the Hamiltonian but how will it transform under the displacement operator?

To determine this, let's compute the commutator of D and H ,

$$[D, H] = DH - HD$$

$$\begin{aligned}[D, H] f(x) &= D\left[-\frac{\hbar^2}{2m} \frac{d^2}{dx^2} + V(x)\right]f(x) - \left[-\frac{\hbar^2}{2m} \frac{d^2}{dx^2} + V(x)\right]Df(x) \\ &= D\left[-\frac{\hbar^2}{2m} f''(x) + V(x)f(x)\right] - \left[-\frac{\hbar^2}{2m} \frac{d^2}{dx^2} + V(x)\right]f(x+a) \\ &= \left[-\frac{\hbar^2}{2m} f''(x+a) + V(x+a)f(x+a)\right] \\ &\quad - \left[-\frac{\hbar^2}{2m} f''(x+a) + V(x+a)f(x+a)\right]\end{aligned}$$

but since $V(x+a) = V(x)$

Properties of the displacement operator

The solution to the Dirac comb must be an eigenfunction of the Hamiltonian but how will it transform under the displacement operator?

To determine this, let's compute the commutator of D and H ,

$$[D, H] = DH - HD$$

$$\begin{aligned}[D, H] f(x) &= D\left[-\frac{\hbar^2}{2m} \frac{d^2}{dx^2} + V(x)\right]f(x) - \left[-\frac{\hbar^2}{2m} \frac{d^2}{dx^2} + V(x)\right]Df(x) \\ &= D\left[-\frac{\hbar^2}{2m} f''(x) + V(x)f(x)\right] - \left[-\frac{\hbar^2}{2m} \frac{d^2}{dx^2} + V(x)\right]f(x+a) \\ &= \left[-\frac{\hbar^2}{2m} f''(x+a) + V(x+a)f(x+a)\right] \\ &\quad - \left[-\frac{\hbar^2}{2m} f''(x+a) + V(x+a)f(x+a)\right] = 0\end{aligned}$$

but since $V(x+a) = V(x)$, H and D commute and we can have simultaneous eigenfunctions of both operators

Bloch functions

The eigenvalue equation for the displacement operator is thus

Bloch functions

The eigenvalue equation for the displacement operator is thus

$$D\psi(x) = \lambda\psi(x)$$

Bloch functions

The eigenvalue equation for the displacement operator is thus

$$D\psi(x) = \lambda\psi(x)$$

$$\psi(x + a) = \lambda\psi(x)$$

Bloch functions

The eigenvalue equation for the displacement operator is thus

since λ cannot be zero, it must be a complex number which can be expressed as a phasor

$$D\psi(x) = \lambda\psi(x)$$

$$\psi(x + a) = \lambda\psi(x)$$

Bloch functions

The eigenvalue equation for the displacement operator is thus

since λ cannot be zero, it must be a complex number which can be expressed as a phasor

$$D\psi(x) = \lambda\psi(x)$$

$$\psi(x+a) = \lambda\psi(x)$$

$$\lambda = e^{iKa}$$

Bloch functions

The eigenvalue equation for the displacement operator is thus

since λ cannot be zero, it must be a complex number which can be expressed as a phasor

we thus have a condition on the wavefunction in a periodic potential

$$D\psi(x) = \lambda\psi(x)$$

$$\psi(x+a) = \lambda\psi(x)$$

$$\lambda = e^{iKa}$$

Bloch functions

The eigenvalue equation for the displacement operator is thus

since λ cannot be zero, it must be a complex number which can be expressed as a phasor

we thus have a condition on the wavefunction in a periodic potential

resulting in Bloch's theorem

$$D\psi(x) = \lambda\psi(x)$$

$$\psi(x + a) = \lambda\psi(x)$$

$$\lambda = e^{iKa}$$

$$\psi(x + a) = e^{iKa}\psi(x)$$

Bloch functions

The eigenvalue equation for the displacement operator is thus

$$D\psi(x) = \lambda\psi(x)$$

since λ cannot be zero, it must be a complex number which can be expressed as a phasor

$$\psi(x+a) = \lambda\psi(x)$$

we thus have a condition on the wavefunction in a periodic potential

$$\lambda = e^{iKa}$$

resulting in Bloch's theorem

$$\psi(x+a) = e^{iKa}\psi(x)$$

Bloch's theorem only applies to an infinitely repeating potential and our goal is to model a macroscopic crystal so the number of repeating units of the potential is of the order of 10^{10}

Bloch functions

The eigenvalue equation for the displacement operator is thus

$$D\psi(x) = \lambda\psi(x)$$

since λ cannot be zero, it must be a complex number which can be expressed as a phasor

$$\psi(x+a) = \lambda\psi(x)$$

we thus have a condition on the wavefunction in a periodic potential

$$\lambda = e^{iKa}$$

resulting in Bloch's theorem

$$\psi(x+a) = e^{iKa}\psi(x)$$

Bloch's theorem only applies to an infinitely repeating potential and our goal is to model a macroscopic crystal so the number of repeating units of the potential is of the order of 10^{10}

by assuming that the edges of the solid are always far away, and applying periodic boundary conditions, Bloch's theorem can be made applicable to the Dirac comb and other models of solids

Periodic boundary conditions

Take N to be the number of “atoms” in the system

Periodic boundary conditions

Take N to be the number of “atoms” in the system
wrap the end of the comb back to that
start to get a periodic boundary condition

Periodic boundary conditions

Take N to be the number of “atoms” in the system
wrap the end of the comb back to that
start to get a periodic boundary condition

$$\psi(x + Na) = \psi(x)$$

Periodic boundary conditions

Take N to be the number of “atoms” in the system

wrap the end of the comb back to that start to get a periodic boundary condition

this is just applying the displacement operator N times and getting, by Bloch's theorem

$$\psi(x + Na) = \psi(x)$$

Periodic boundary conditions

Take N to be the number of “atoms” in the system

wrap the end of the comb back to that start to get a periodic boundary condition

this is just applying the displacement operator N times and getting, by Bloch's theorem

$$\psi(x + Na) = \psi(x)$$

$$e^{iNKa}\psi(x) = \psi(x)$$

Periodic boundary conditions

Take N to be the number of “atoms” in the system

wrap the end of the comb back to that start to get a periodic boundary condition

this is just applying the displacement operator N times and getting, by Bloch's theorem

$$\psi(x + Na) = \psi(x)$$

$$e^{iNKa}\psi(x) = \psi(x)$$

$$e^{iNKa} = 1$$

Periodic boundary conditions

Take N to be the number of “atoms” in the system

wrap the end of the comb back to that start to get a periodic boundary condition

this is just applying the displacement operator N times and getting, by Bloch's theorem

$$\psi(x + Na) = \psi(x)$$

$$e^{iNKa}\psi(x) = \psi(x)$$

$$e^{iNKa} = 1$$

$$NKa = 2\pi n$$

Periodic boundary conditions

Take N to be the number of “atoms” in the system

wrap the end of the comb back to that start to get a periodic boundary condition

this is just applying the displacement operator N times and getting, by Bloch's theorem

leading to quantization of the factor K , which is clearly similar to the wave number in the free electron gas model

$$\psi(x + Na) = \psi(x)$$

$$e^{iNKa} \psi(x) = \psi(x)$$

$$e^{iNKa} = 1$$

$$NKa = 2\pi n$$

Periodic boundary conditions

Take N to be the number of “atoms” in the system

wrap the end of the comb back to that start to get a periodic boundary condition

this is just applying the displacement operator N times and getting, by Bloch's theorem

leading to quantization of the factor K , which is clearly similar to the wave number in the free electron gas model

$$\psi(x + Na) = \psi(x)$$

$$e^{iNKa} \psi(x) = \psi(x)$$

$$e^{iNKa} = 1$$

$$NKa = 2\pi n$$

$$K = \frac{2\pi n}{Na}, \quad (n = 0, \pm 1, \pm 2, \dots)$$